

Mounting Accessories for Cylinders

Adjustable hydraulic shock absorbers



Standard executions		
Version	Symbol	Type
Without mechanical stopper		DR
With mechanical stopper included		DRF



Series of adjustable hydraulic shock absorbers. They absorb the impact energy on the rod by the displacement of oil from one chamber to another inside the body of the cushioning.

This displacement is controlled by a valve and a throttling mechanism according to the adjustment brought in.

The adjustment is carried out by a nut set in the rear end.

The adjusting field is from 0 to 9 and the nut is provided with a stopper grub screw.

The optimal cushion is obtained:

1. If the cushion is too high at the beginning of the stroke, move the nut towards 9.
2. If the cushion is too high near the end of the stroke, move the nut towards 0.

For selection of shock absorbers see page 1.105.2.

In the version without mechanical stopper the cushioning must be provided with an external one (mechanical stopper) set at 0,5 - 1 mm before the end of the stroke.

Technical data	
Temperature range	Type DR: + 5 °C ÷ + 70°C Type DRF: + 12 °C ÷ + 90°C
Materials	Body: Burnished steel Rod: Stainless steel Spring: Steel Seals: Nitrile rubber (NBR) - Polyurethane, Elastomer
Maximum impact velocity	4 m/s

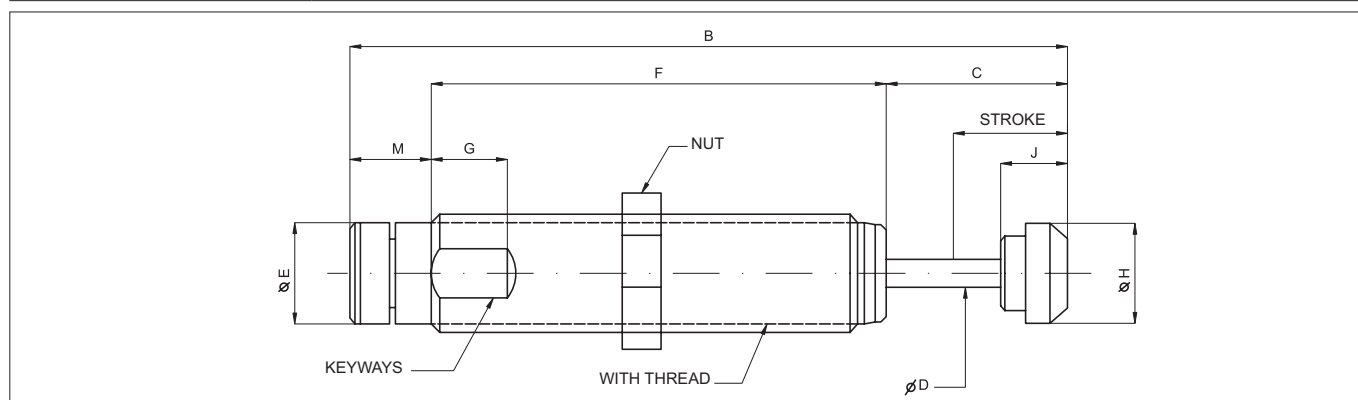

Code	Item	Stroke	A	B	C	D	E	F	G	H	I	J	M	CH	Maximum absorbing capacity (Nm)		Efficiency measurement		Weight (g)
															Per cycle (W3)	Per hour (W4)	minimum (Kg.)	maximum (Kg.)	
041801	DR1008	8	10x1	66,5	14,5	2,5	8,8	40	-	6	-	6,5	12	13	1,8	3600	0,2	10	26
041802	DR1210	10	12x1	84	18	3,5	10,8	60	-	8	-	8	6	14	4	6000	0,9	57	43
041803	DRF1412	12,5	14x1,5	87	17,5	8	12	61	12	12	12	10	8,5	17	17	35000	0,6	90	60
041804	DRF2019	19,1	20x1,5	117,9	30	4,8	16,8	74,7	12,7	16,8	18	11	13,2	24	25	45000	2,3	226	130
041805	DRF2525	25,4	25x1,5	142,6	36,3	6,3	22,4	89,7	12,7	22,9	23	11	16,6	30	88	68000	9	1360	310
041806	DRF2540	40	25x1,5	189	51,1	6,3	22,4	121,3	12,7	22,9	23	11	16,6	30	100	90000	14	2040	400



FACTORS

Symbol

W1 = Kinetic energy per cycle	(Nm)
W2 = Motive energy per cycle	(Nm)
W3 = Total energy per cycle	(Nm)
W4 = Total energy per hour	(Nm/h)
F = Motive power	(N)
x = Number of cycles per hour	(1/h)
s = Cushioning length	(m)
v = Mass velocity	(m/s)
m = Cushioned mass	(Kg)
ME = Efficiency measurement	(Kg)

The shock absorbers are selected according to their energy absorbing capacity.

The capacity values identify both the mass that can be cushioned and the energy that can be absorbed per cycle and hour. So the required performances must be compared with the table of the cushionings capacities to make sure that the energy can be absorbed, converted into heat and dissipated in the atmosphere.

Energy - The factors that must be considered at the moment of selection are:

- Kinetic energy (W1): it is the energy generated by the weight and the velocity of the mass that must be cushioned.
- Motive energy (W2): it is the work, produced by the motive power acting on the mass that must be cushioned, multiplied by the cushion length.
- Total energy per cycle (W3): it is the sum of the 2 preceding values and is the energy that must be dissipated every cycle.
- Total energy per hour (W4): it is the product of the total energy per cycle by the number of cycles per hour; so it is the energy the cushioning must dissipate every hour.
- Efficiency measurement (ME): it is the mass (theoretical), which, without motive power and at the same velocity of the real mass, would have a kinetic energy equal to the total energy per cycle (W3) of the real application. It is not the mass that must be cushioned; it doesn't indicate the power supported by the cushioning.

HOW TO CHOOSE

The choice of the optimal cushioning can be easily made by the procedure shown here.

In any case our technicians are always at your disposal to help you to choose the fittest cushioning, to solve limit applications or study special solutions.

- 1) Precisely determine the data of the problem, that is the calculus factors m, v, F, x, s shown above.
- 2) Calculate the kinetic energy of the mass:
 $W_1 = 0,5 \cdot m \cdot v^2$ (Nm).
 Choose a cushioning with a capacity per cycle higher than the calculated value. The cushion length chosen must be used at point 3).
- 3) If there is an external motive power (hydraulic or pneumatic cylinder, motor, gravity, etc.) calculate the work done:
 $W_2 = F \cdot s$ (Nm).
- 4) Calculate the total energy that must be dissipated per cycle.
 $W_3 = W_1 + W_2$ (Nm).
 Check that the value obtained is within the capacity limits of the chosen cushioning.
 Otherwise you must consider a cushioning with higher cushion length or diameter and in case calculate W_2 and W_3 again.
 It can be necessary to compare cushionings with different cushion lengths and do the calculus again each time.
- 5) It is better to choose a cushioning with a capacity 25 per cent higher than the required one in order to:
 - a) Let following possible increases of the impact energy.
 - b) Work with safe margins when velocities are not easily valuable.
 - c) Make sure that the cushioning lasts long, especially when working in dusty or contaminated environments.

- 6) Calculate the efficiency measurement:

$$ME = \frac{W_3 \cdot 2}{V_2} \text{ (Kg)}$$

Check that the value obtained is within the limits indicated for the chosen cushioning and this to get a linear and progressive cushion.

- 7) Were the "ME" out of the limits, you should choose a cushioning with a different capacity of efficiency measurement. Varying the cushion length you can change the "ME"; however, at each variation of the cushion length you must remember to calculate the propelling energy of the point 3 again.
- 8) Check whether the cushioning is condition to dissipate the energy generated by work frequency per hour into heat:

$$W_4 = W_3 \cdot X \text{ (Nm/h)}$$

- 9) Were the cushioning not in condition to dissipate it, you should choose among:
 - a) Use of a cushioning with a higher capacity per hour taking care of calculating the point 3 again (were the cushion length different).
 - b) Use of a system with recirculation or external air/oil tank, both characterised by a higher capacity per hour
 - c) Cooling of the cushioning by air blow or another refrigerating fluid.