

Version	Type
Unidirectional in line with female-female thread	VX52
Bi-directional in line with female-female thread	VX53
Hexagonal screw adjustment	VX15
For cylinder, swivel with screwdriver adjustment and push-in fitting	VX18



Series of stainless steel flow controls available either for in line applications and for direct connection to cylinders to control the translation velocity.

The in line regulators are available for control in one way (unidirectional) or in both ways (bi-directional).

The regulators for cylinders can be unidirectional with outlet adjustment from the cylinder (C) or with inlet adjustment to the cylinder (V), and in both sides (B).

For standard items, codes and dimensions see tables at page 5.185.2.

For the coupling of the screw adjustment type VX15 with stainless steel single banjo, see banjo type RX35 at page 5.150.5

Flow diagrams

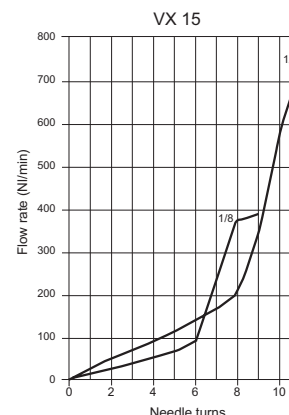
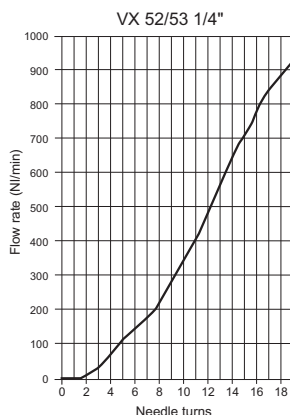
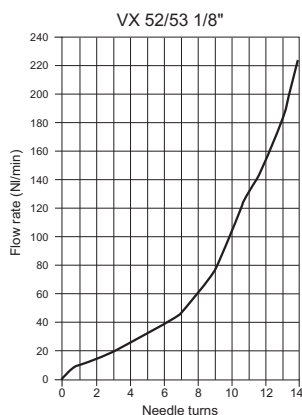

Technical data

Type	VX52 - VX53	VX15	VX18
Fluid	Compressed filtered air with or without lubrication		
Pressure range	0,5 ÷ 10 bar	0 ÷ 10 bar	
Temperature range	-20 °C ÷ 150 °C		0 °C ÷ 150 °C
Threads	UNI - ISO 228		
Materials	Body: Stainless Steel AISI 316 L Needle & needle valve: Stainless steel AISI 316 L Knob: Stainless steel AISI 316 L Nut: Stainless steel AISI 316 L Seals: FPM	Body: Stainless Steel AISI 316 L Needle: Stainless steel AISI 316 L Cartridge: Stainless steel AISI 316 L Seals: FPM Gasket: PTFE	Body: Stainless Steel AISI 316 L Needle: Stainless steel AISI 316 L Cartridge: Stainless steel AISI 316 L Seals: FPM Banjo ring: Stainless steel AISI 316 L

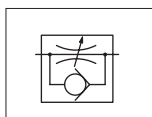
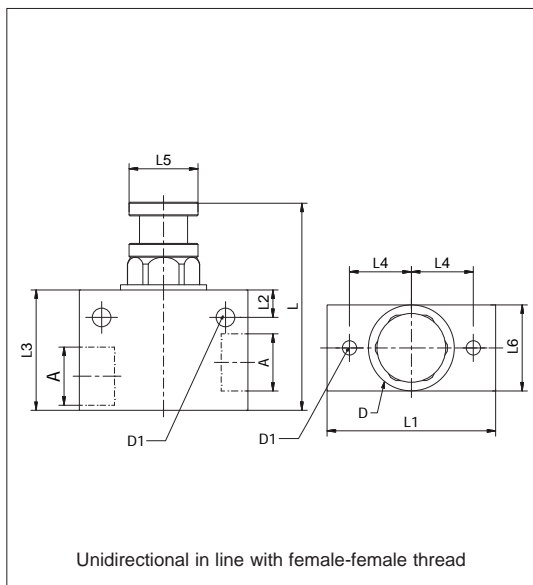

Code	Item	A	L		L ₁	L ₂	L ₃	L ₄	L ₅	L ₅	D Ø	D ₁ Ø	Weight gr
			min	max									
030155	VX52 18 18	1/8"	49	54	40	8	30	15	20	20	5,4	M5	168
030156	VX52 14 14	1/4"	49	54	40	8	30	15	20	20	5,4	M5	178
030146	VX52 38 38	3/8"	57	66	49	8	35	18	20	25	5,4	M5	305
030147	VX52 12 12	1/2"	57	66	49	8	35	18	20	25	5,4	M5	310

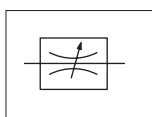
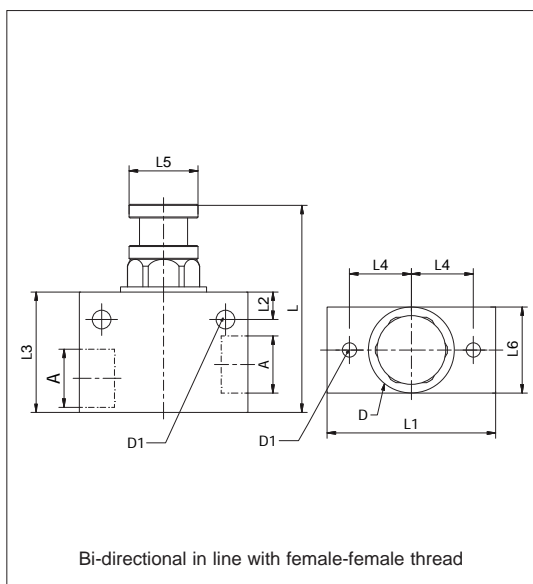

Code	Item	A	L		L ₁	L ₂	L ₃	L ₄	L ₅	L ₅	D Ø	D ₁ Ø	Weight gr
			min	max									
030157	VX53 18 18	1/8"	49	54	40	8	30	15	20	20	5,4	M5	168
030158	VX53 14 14	1/4"	49	54	40	8	30	15	20	20	5,4	M5	178
030144	VX53 38 38	3/8"	57	66	49	8	35	18	20	25	5,4	M5	305
030148	VX53 12 12	1/2"	57	66	49	8	35	18	20	25	5,4	M5	310

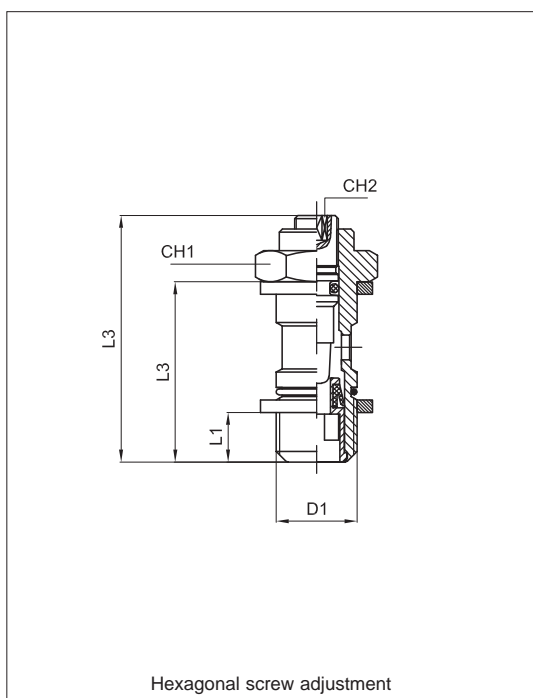

For cylinder

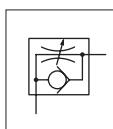

Code	Item	D ₁	L ₁	L ₂	L ₃ max	CH ₁	CH ₂	Weight gr
024035	VX15 00 18C	1/8"	5,5	25	36	14	2,5	16
024036	VX15 00 14C	1/4"	6,5	27,5	42	17	3	30

For banjo push-in fittings series RX

see page 5.150.5.

Bi directional

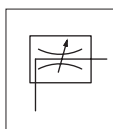

Code	Item	D ₁	L ₁	L ₂	L ₃ max	CH ₁	CH ₂	Weight gr
024037	VX15 00 18B	1/8"	5,5	25	36	14	2,5	16
024038	VX15 00 14B	1/4"	6,5	27,5	42	17	3	30

For banjo push-in fittings series RX

see page 5.150.5.

For valve

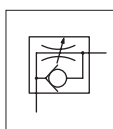

Code	Item	D ₁	L ₁	L ₂	L ₃ max	CH ₁	CH ₂	Weight gr
024039	VX15 00 18V	1/8"	5,5	25	36	14	2,5	16
024040	VX15 00 14V	1/4"	6,5	27,5	42	17	3	30

For banjo push-in fittings series RX

see page 5.150.5.

For cylinder

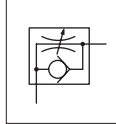

Code	Item	Tube ø	D1	D2	L1	L2	L3 max	L4	CH	Weight gr
024232	VX180418C	4	1/8"	9	5	15.5	32	19,5	9	29
024233	VX180618C	6	1/8"	12	5	15.5	32	22	9	27
024234	VX180614C	6	1/4"	12	6.5	17.5	40	23,5	10	49
024235	VX180818C	8	1/8"	14	5	15.5	32	22,5	9	31
024236	VX180814C	8	1/4"	14	6.5	17.5	40	24	10	49
024237	VX181014C	10	1/4"	16	6.5	17.5	40	26,5	10	53
024238	VX181038C	10	3/8"	16	9	22	52	28	14	86

For valves

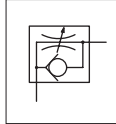

Code	Item	Tube ø	D1	D2	L1	L2	L3 max	L4	CH	Weight gr
024239	VX180418V	4	1/8"	9	5	15.5	32	19,5	9	29
024240	VX180618V	6	1/8"	12	5	15.5	32	22	9	27
024241	VX180614V	6	1/4"	12	6.5	17.5	40	23,5	10	49
024242	VX180818V	8	1/8"	14	5	15.5	32	22,5	9	31
024243	VX180814V	8	1/4"	14	6.5	17.5	40	24	10	49
024244	VX181014V	10	1/4"	16	6.5	17.5	40	26,5	10	53
024245	VX181038V	10	3/8"	16	9	22	52	28	14	86

Bi directional

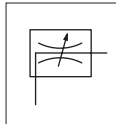

Code	Item	Tube ø	D1	D2	L1	L2	L3 max	L4	CH	Weight gr
024246	VX180418B	4	1/8"	9	5	15.5	32	19,5	9	29
024247	VX180618B	6	1/8"	12	5	15.5	32	22	9	27
024248	VX180614B	6	1/4"	12	6.5	17.5	40	23,5	10	49
024249	VX180818B	8	1/8"	14	5	15.5	32	22,5	9	31
024250	VX180814B	8	1/4"	14	6.5	17.5	40	24	10	49
024251	VX181014B	10	1/4"	16	6.5	17.5	40	26,5	10	53
024252	VX181038B	10	3/8"	16	9	22	52	28	14	86

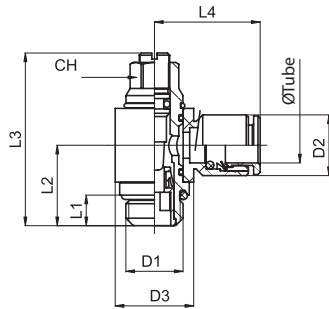

Swivel with push-in fitting

Flow diagrams

